

# Instruction Sheet

## VIQUA Water Filters Installation

### Section 1 Safety Information

Please read this entire instruction sheet before operating this equipment. Pay attention to all danger, warning, and caution statements in this instruction sheet. Failure to do so could result in serious personal injury or damage to the equipment.

Make sure that the protection provided by this equipment is not impaired. Do not use or install this equipment in any manner other than that specified in the instruction sheet.

#### 1.1 Safety Precautions

#### ⚠ WARNING



**WARNING:** This product can expose you to chemicals including phthalates, which is known to the state of California to cause cancer, and mercury, which is known to the State of California to cause birth defects or other reproductive harm. For more information go to [www.P65Warnings.ca.gov](http://www.P65Warnings.ca.gov).

#### ⚠ CAUTION



If water pipes are used to ground electrical system, appliances, or phone, install a jumper wire.

#### NOTICE



Read and understand this Instruction Sheet before operating and performing any maintenance on this equipment.

### Section 2 Installation

#### ⚠ WARNING

- DO NOT install on line pressures above 100 psi (6.9 bar).
- DO NOT overtighten pipe fittings.
- DO NOT use wicking or sealer, Teflon™ tape is recommended.
- DO NOT use torch near plastic housing. All sweated joints should be made prior to assembling piping to the filter head.
- Replace O-ring seal, if there is visible damage.
- Maximum temperature allowed is 38 °C (100 °F). Special hot water filters are available for higher temperatures.
- Protect the filters from freezing temperatures.
- DO NOT install in direct sunlight.
- Allow minimum of 2" clear space under filter to facilitate cartridge change.
- DO NOT use with water that is microbiologically unsafe or of unknown quality without adequate disinfection before or after the system.



AWP40B-V, AWP42B-V, AWP50B-V and AWP52B-V are Tested and Certified by NSF International against NSF/ANSI standard 42 for material and structural integrity requirements.

## 2.1 Installing Filter on Water Line

### NOTICE

Before starting, shut off the main water supply and drain pipes.

**Note:** Filter can be adapted to various pipes using reducing adapters on either end. Installation fittings can be sweated or threaded. Use galvanized fittings for installation on galvanized pipe.

#### Procedure:

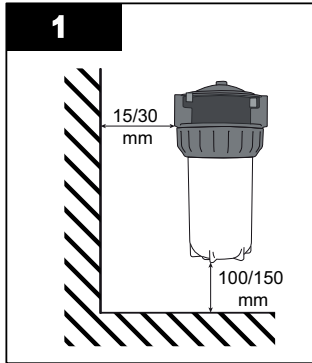

- Install the filters at a minimum distance of 15-30 mm from the wall and 100-150 mm from the ground.

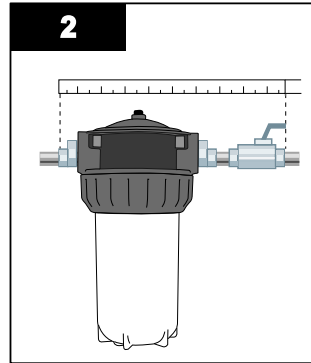

- Loosen all parts and calculate length of pipe to be removed.
- Cut the pipe and install fittings onto pipe.

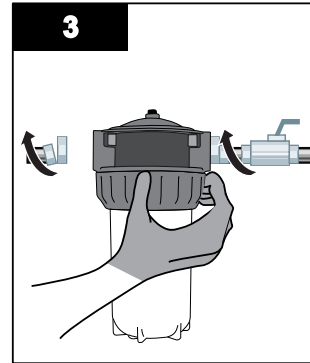

- Screw filter to the adapter after covering the threads with Teflon™ tape and make a tight connection but do not over tighten.

**Note:** If space is limited remove sump from head while making connection.

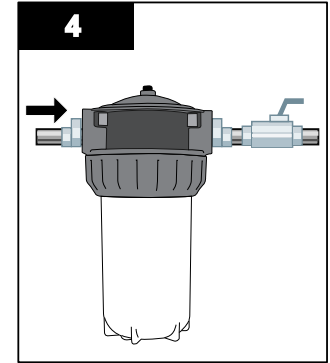

- Connect and tighten, making sure filter is in a straight vertical position.

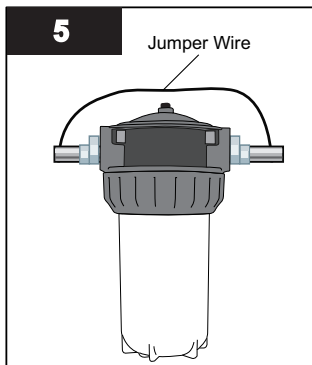

**Note:** If water pipes are used to ground electrical system, appliances, or phone, install a jumper wire.

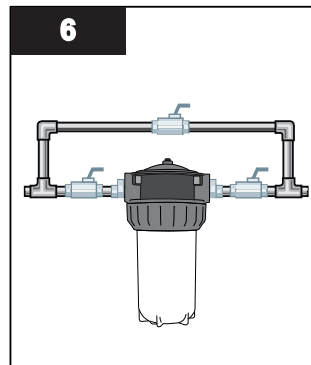

By-pass section:

- Use either threaded or sweated fittings for bypass section (optional).

## Section 3 Maintenance

### 3.1 Cartridge Replacement

Replace cartridge when there is a noticeable drop in water flow at the faucet or tap.

Procedure:

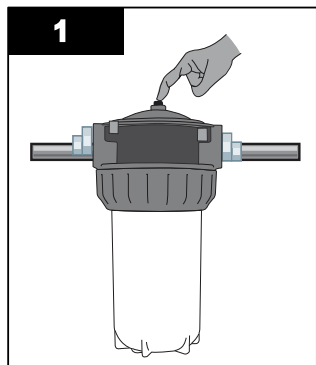

- Shut off inlet and outlet valves.
- Depress pressure relief button on top of filter head to relieve pressure in filter.

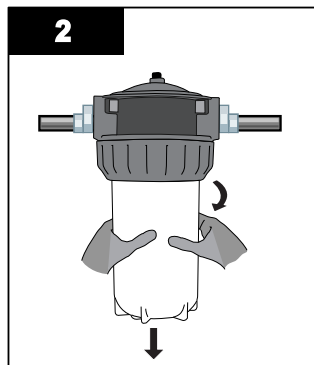

- Unscrew ring nut and separate from outer head.
- Remove cartridge emptying water from sump.

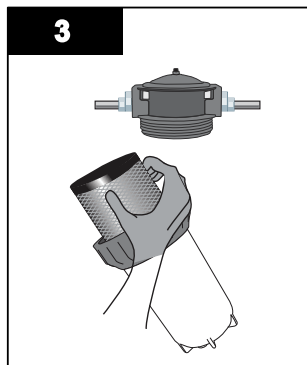

- Clean and inspect all components.
- Lubricate O-rings with a light coating of a silicone based lubricant. Replace O-ring seal if there is visible damage.
- Install new VIQUA cartridge into sump.

**Note:** VIQUA cartridges are designed and manufactured to provide the best possible performance. Use of non VIQUA cartridges may result in system failure.

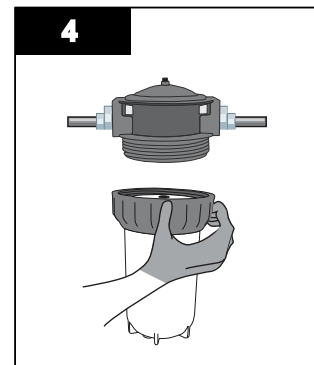

- Place lubricated O-ring on the sump.
- Using supplied wrench, tighten sump firmly onto the head until a definite stop is felt and the cartridge is sealed.

**Note:** Do not overtighten the sump.

- Turn on inlet valve and depress pressure relief button until air is purged from filter.
- Release button and turn on outlet valve.

## Section 4 Replacement Parts

Parts	Description	Part Number
	Cartridge	Sediment - CMB510-HF, Grooved
		Sediment - CMB-110-HF, Ungrooved
		Taste/Odour - C2-01
	Two-High	Sediment - CMB520-HF, Grooved
		Sediment - CMB-120-HF, Ungrooved
		Taste/Odour - C2-02
	O-ring	<b>1</b> OR40-50W for Filters AWP40B-V, AWP42B-V, AWP50B-V, AWP52B-V. <b>2</b> OR40-50C for Filters AWP40C-V.
	Wrench	WR40-50



425 Clair Rd. W, Guelph, Ontario, Canada N1L 1R1  
t. (+1) 519.763.1032 • tf. (+1) 800.265.7246 (US and Canada only)  
t. (+31) 73 747 0144 (Europe only) • f. (+1) 519.763.5069  
e-mail: [info@viqua.com](mailto:info@viqua.com)  
[www.viqua.com](http://www.viqua.com)

**FR**  
Cet appareil se recycle

À DÉPOSER EN MAGASIN **OU** À DÉPOSER EN DÉCHÈTERIE

Points de collecte sur [www.quefairedemesdechets.fr](http://www.quefairedemesdechets.fr)  
Privilégiez la réparation ou le don de votre appareil !

The block contains several icons: a circular icon of a person recycling, a storefront icon representing a shop, and a recycling symbol icon representing a waste management facility.