

# Instruction Sheet

## VIQUA UV Lamp and Quartz Sleeve Replacement

**Model:** Hi-Flo

Read and observe all labels attached to product. See further directions for use, precautionary statements, storage and disposal information in system product manual.

The UV systems inactivates Cryptosporidium, Giardia, Escherichia coli (E. Coli) and Fecal Coliform.

### Overview

**UV Lamp replacement:** The amount of UV light created by the UV lamp decreases over time, requiring that the UV lamp be replaced. The system will automatically notify you when it is time to replace the UV lamp.

**Quartz Sleeve replacement/maintenance:** Minerals in the water slowly form a coating on the quartz sleeve. This coating must be removed because it reduces the amount of UV light reaching the water, thereby reducing performance. If the quartz sleeve cannot be clean. It must be replaced.

## Section 1 Safety Information

Please read this entire instruction sheet before operating this equipment. Pay attention to all danger, warning, and caution statements. Failure to do so could result in serious personal injury or damage to the equipment.

Make sure that the protection provided by this equipment is not impaired. Do not use or install this equipment in any manner other than that specified in the instruction sheet.

### 1.1 Safety Precautions

#### ⚠ DANGER



Failure to follow these instructions will result in serious injury or death.

#### **Shock Hazard - Stored Energy**



- Disconnect power to system before performing any maintenance or repair.



- There may be more than one source of power. Only connect to a GFCI.



- Protective ground



- DO NOT touch with wet hands.

#### **Pressurized Device - Impalement Hazard**



- NEVER perform any physical inspection, repair or maintenance on UV chamber unless UV chamber has been isolated and depressurized.



- NEVER service UV lamps, quartz sleeves or associated hardware until depressurization of UV chamber has been confirmed.



- DO NOT store any combustible or flammable material close to the system.

### ⚠ WARNING

Failure to follow these instructions could result in serious injury or death.

#### **UV Light Hazard**



- ALWAYS use UV protective gear, including gloves and UV safety glasses.
- NEVER look directly at illuminated UV lamp, even when using protective gear.
- NEVER illuminate UV lamp outside of the UV chamber.
- If accidental exposure occurs, immediately cool affected area and consult physician.

#### **Contamination Hazard**



- If UV lamp breaks, avoid inhalation, ingestion, or exposure to eyes and skin. Wear appropriate clothing and personal protective equipment.
- NEVER use a vacuum cleaner to clean up broken UV lamps as this will scatter the mercury. Obey local regulations and guidelines for the removal and disposal of mercury waste.



**WARNING:** This product can expose you to chemicals including Phthalates, which are known to the State of California to cause cancer and birth defects or other reproductive harm. For more information go to [www.P65Warnings.ca.gov](http://www.P65Warnings.ca.gov).

### ⚠ CAUTION

Failure to follow these instructions could result in minor or moderate injury.

#### **Thermal Hazard**



- Allow UV lamps, UV chamber to cool for a minimum of 10 (ten) minutes before handling.
- When there is no water flow, the water in the chamber will become hot. To prevent scalding, allow the system to cool for 10 minutes before draining the system.

#### **Personal Injury Hazard**



- UV lamps and quartz sleeves are fragile. Do not strike, bend or apply pressure, or they will break.
- DO NOT handle UV lamps or quartz sleeves with bare hands. Wear rubber or latex gloves to handle previously installed UV lamps and soiled quartz sleeves to protect against contaminants. Wear cotton gloves to handle new UV lamps and clean quartz sleeves.

#### **Hg Exposure**



- The UV lamp contains mercury. If the lamp breaks, then avoid inhalation or ingestion of the debris and avoid exposure to eyes and skin. Never use a vacuum cleaner to clean up a broken lamp as this may scatter the spilled mercury. Obey local regulations and guidelines for the removal and disposal of mercury waste.

### NOTICE

#### **System Protection**



- To protect the Controller, a UL 1449 certified (or equivalent) transient voltage surge suppressor is strongly recommended.

#### **Avoid Injury**

- Read and understand this Instruction Sheet before operating and performing any maintenance on this equipment.

## Section 2 Maintenance

### ⚠ WARNING



- Always disconnect power before performing any work on the UV system.
- Always shut-off water flow and release water pressure before servicing.
- Regularly inspect your UV system to ensure that the power indicators are on and no alarms are present.
- Replace the UV lamp annually (or biennially if seasonal home use) to ensure maximum performance.
- Always drain the chamber when closing a seasonal home or leaving the unit in an area subject to freezing temperatures.

### 2.1 Replacing UV Lamp

### NOTICE

Do not use water during replacement of UV lamp.

Lamp replacement is a quick and simple procedure requiring no special tools. The UV lamp must be replaced after 9000 hours of continuous operation (approximately one year) in order to ensure adequate performance.

#### Procedure:

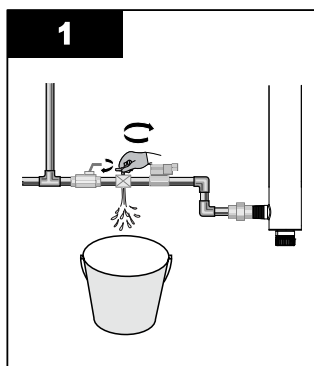

- Shut off the water line to chamber and release system pressure before servicing.
- Close all faucets.

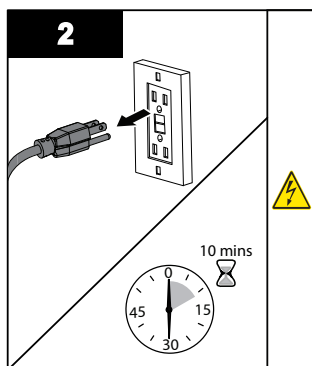

- Disconnect main power source and allow the unit to cool for 10 minutes.

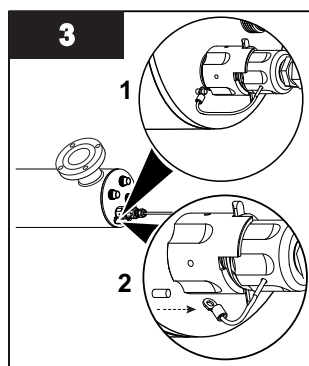

- Disconnect the lamp connector and UV lamp from the retaining nut.

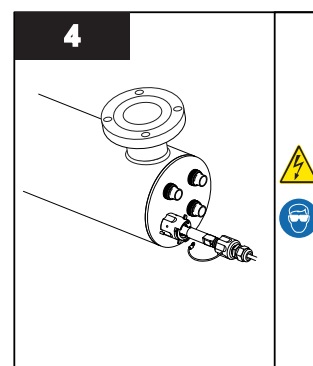

- Rotate the retaining clip locking tabs to unlock the lamp connector.
- Pull the lamp connector along with the UV lamp from the retaining nut.

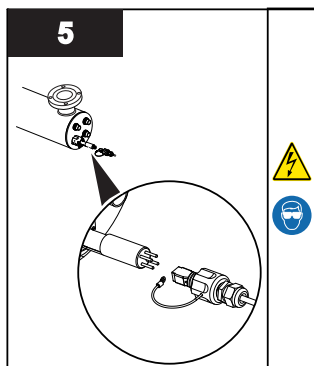

- Disconnect the lamp connector from the UV lamp.

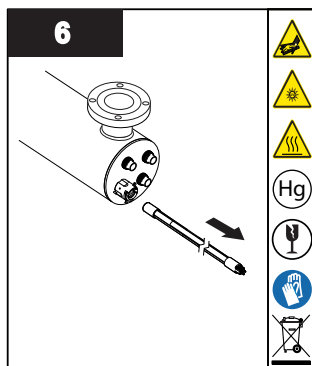

- Remove the UV lamp without twisting and discard the lamp.  
**Note:** Always hold the UV lamp at the ceramic ends.

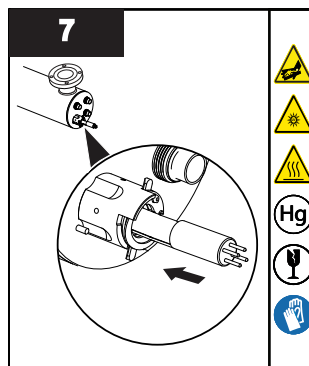

- Insert the new lamp fully into the sleeve leaving about two inches of the lamp protruding from the chamber.

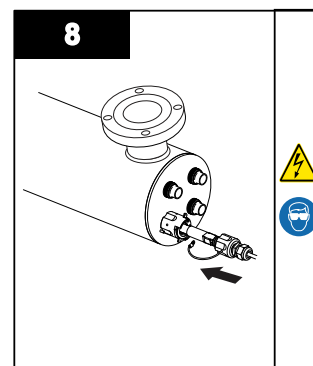

- Connect the lamp connector to the UV lamp.

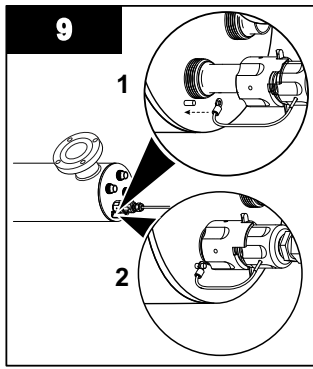

- Slide the lamp connector up to the retaining nut.
- Rotate the retaining nut locking tabs to lock the lamp connector in place.
- Connect the ground cable and restore power.

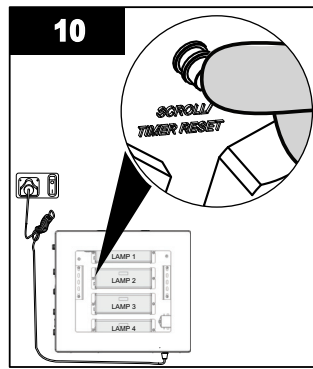

- Hold down the timer reset button and reapply power to the controller until you see **[-5E-]**, then release timer reset button.
- A 5 second delay will occur until you hear an audible tone and LED display will read once again **[365]**.

**Note:** For LAMP 1 replacement, it must be ensured that the lamp wires do not interfere with the UV sensor detection, as low UV alarms could result in Hi-Flo Monitored systems. The two wires should be oriented furthest away from the sensor port. Ensure the connector is fully seated onto the UV lamp.

## 2.2 Cleaning and Replacing Quartz Sleeve

**Note:** Minerals in the water slowly form a coating on the quartz sleeve. This coating must be removed because it reduces the amount of UV light reaching the water, thereby reducing performance. If the sleeve can not be cleaned, it must be replaced.

### Prerequisites:

- Disconnect the main power source and allow the system to cool for 10 minutes.
- Shut off water supply and drain all lines.
- Depressurize the unit. Place a small pail near the openings to catch any spills.
- Remove the UV lamp. Refer to [Section 2.1](#).

### Procedure:

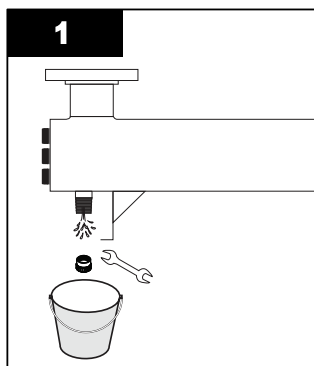

- Remove drain port plug from chamber and drain the water. Replace drain port plug once chamber is drained.

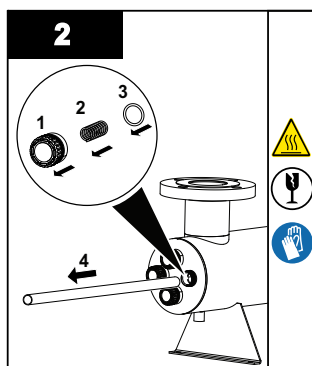

- Remove both retaining nuts, spring and O-ring.
- Carefully, remove the quartz sleeve and second O-ring from the other end.

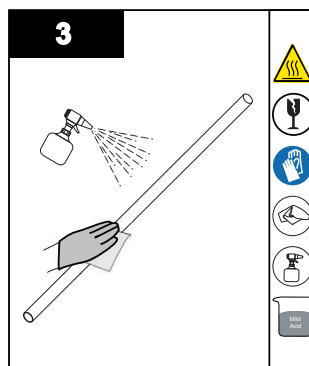

- Clean the quartz sleeve with a cloth soaked in CLR, vinegar or some other mild acid and then rinse with water.

**Note:** If sleeve cannot be cleaned completely or it is scratched or cracked, then replace the sleeve.



- Reinstall the quartz sleeve with lubricated O-rings, followed by spring and retaining nut.

**Note:** Use the supplied O-rings.

- When service is complete, assemble the prerequisites in the reverse order of disassembly.

**Notes:** 1) After replacing the UV lamp or quartz sleeve perform the cleaning procedure; refer to Owner's Manual.

2) If the system is put on a temporary by-pass or if it becomes contaminated after the UV system, it is necessary to shock the system with household bleach for a full 20 minutes before resuming the use of water.

### 2.3 Cleaning and Replacing UV Sensor

#### ⚠ WARNING



The UV sensor is very delicate instrument. Extreme care is required when handling and cleaning. The sensor window itself is constructed from quartz which is extremely fragile, be careful you do not chip or break this quartz window. Manufacturer's warranty does not cover damage due to neglect or misuse.

Mineral deposits and sediment may accumulate on the sensor window decreasing the UV energy detected. Good maintenance of pre-treatment equipment will reduce the accumulation of residues. If the system indicates that the UV intensity is low, one cause may be a stained quartz sleeve and/or sensor window.

#### Prerequisites:

- Disconnect the main power source and allow the system to cool for 10 minutes.
- Shut off water supply and drain all lines.
- Depressurize the unit. Place a small pail near the openings to catch any spills.
- Remove the UV lamp. Refer to [Section 2.1](#).
- Remove and clean the quartz sleeve. Refer to [Section 2.2](#).

**Note:** The quartz sleeve and UV sensor should be cleaned at the same time.

#### Procedure:

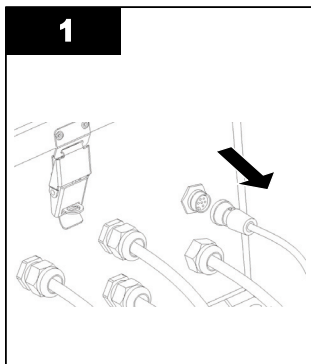

- Disconnect the UV sensor from the controller by disconnecting the sensor cable.

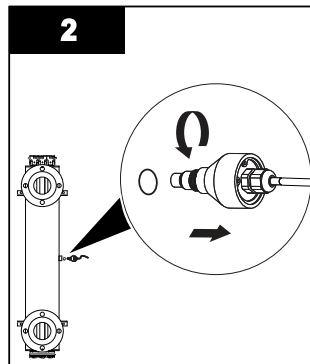

- Remove the UV sensor and O-ring by grasping the body of the sensor and rotating it counter-clockwise.

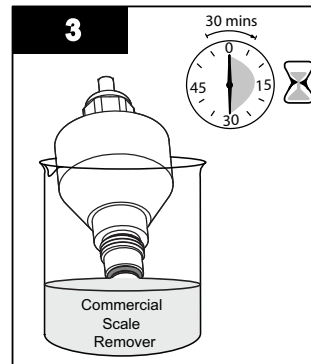

- Submerge only the end of the sensor in the commercial scale remover for 30 minutes.

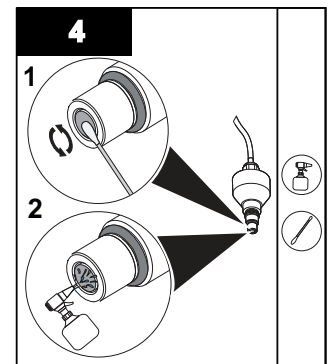

- Clean the sensor with a cotton swab and spray with water.
- Re-insert the UV sensor along with the O-ring until a water-tight seal is achieved.



425 Clair Rd. W, Guelph, Ontario, Canada N1L 1R1  
t. (+1) 519.763.1032 • tf. (+1) 800.265.7246 (US and Canada only)  
t. (+31) 73 747 0144 (Europe only) • f. (+1) 519.763.5069  
e-mail: [info@viqua.com](mailto:info@viqua.com)  
[www.viqua.com](http://www.viqua.com)

